

The future of large power electric transmission

Carlo Rubbia
*Institute for Advanced Sustainability Studies
Potsdam, Germany*

Foreword

- Most of production facilities from renewable energies are situated in suitably chosen areas of substantial size, which are often located far away from densely populated areas.
- The world-wide deployment of these new forms of electricity like wind, geothermal or solar cannot occur without a renewed investment in the transmission infrastructures.
- New connections should be built to link areas with vast potential to generate clean electricity to the areas that have demands for electric power.
- The presently foreseen system is based on High voltage DC (HVDC) overhead lines in the vicinity of 750-800 kV.
- Many thousand of kilometres with tall and massive towers supporting the lines at distances of up to 3000 km are currently operational or under development in the world.

Projects for China (ABB)

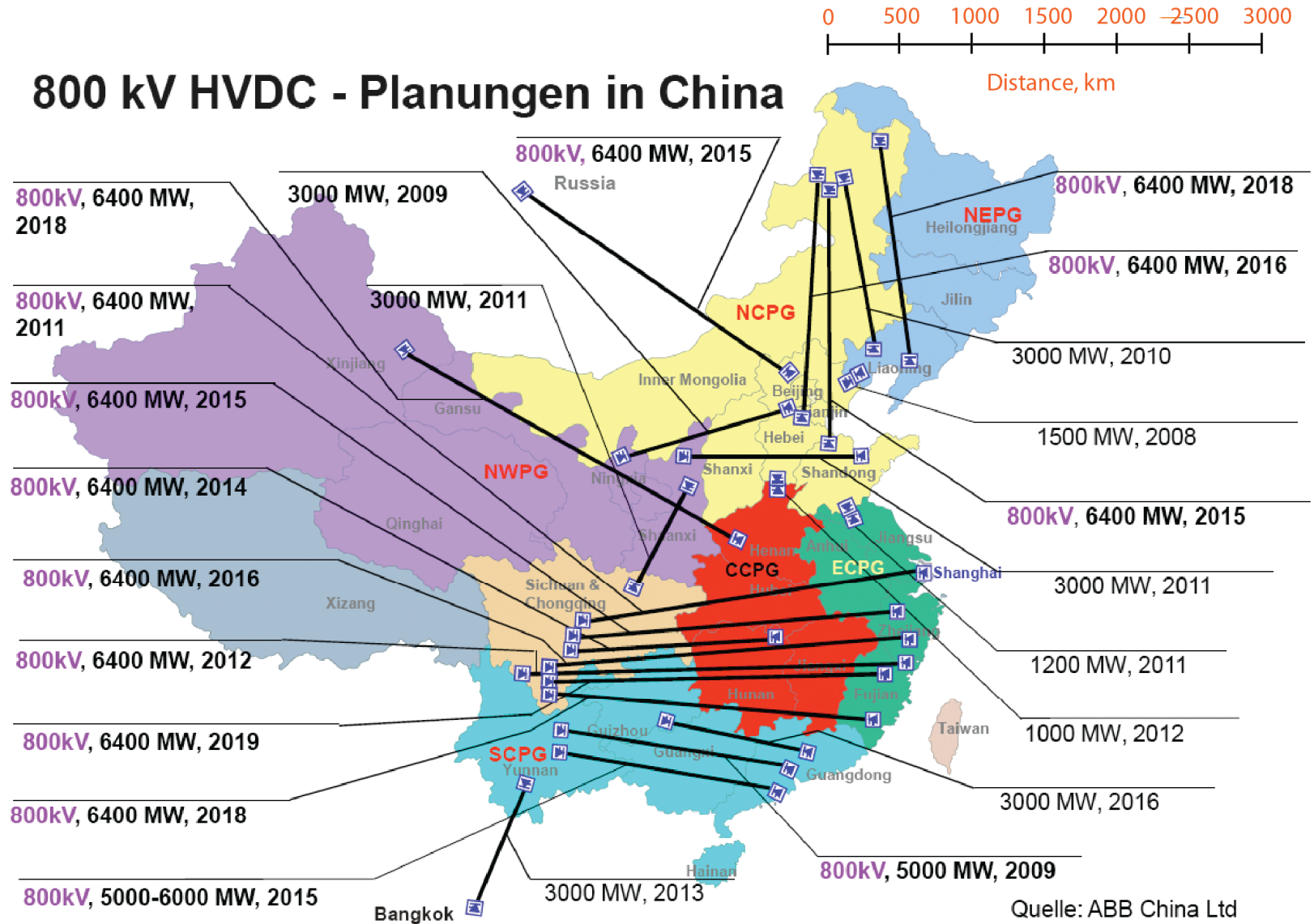

Planned 800 kV HVDC lines in China

The EUMENA project

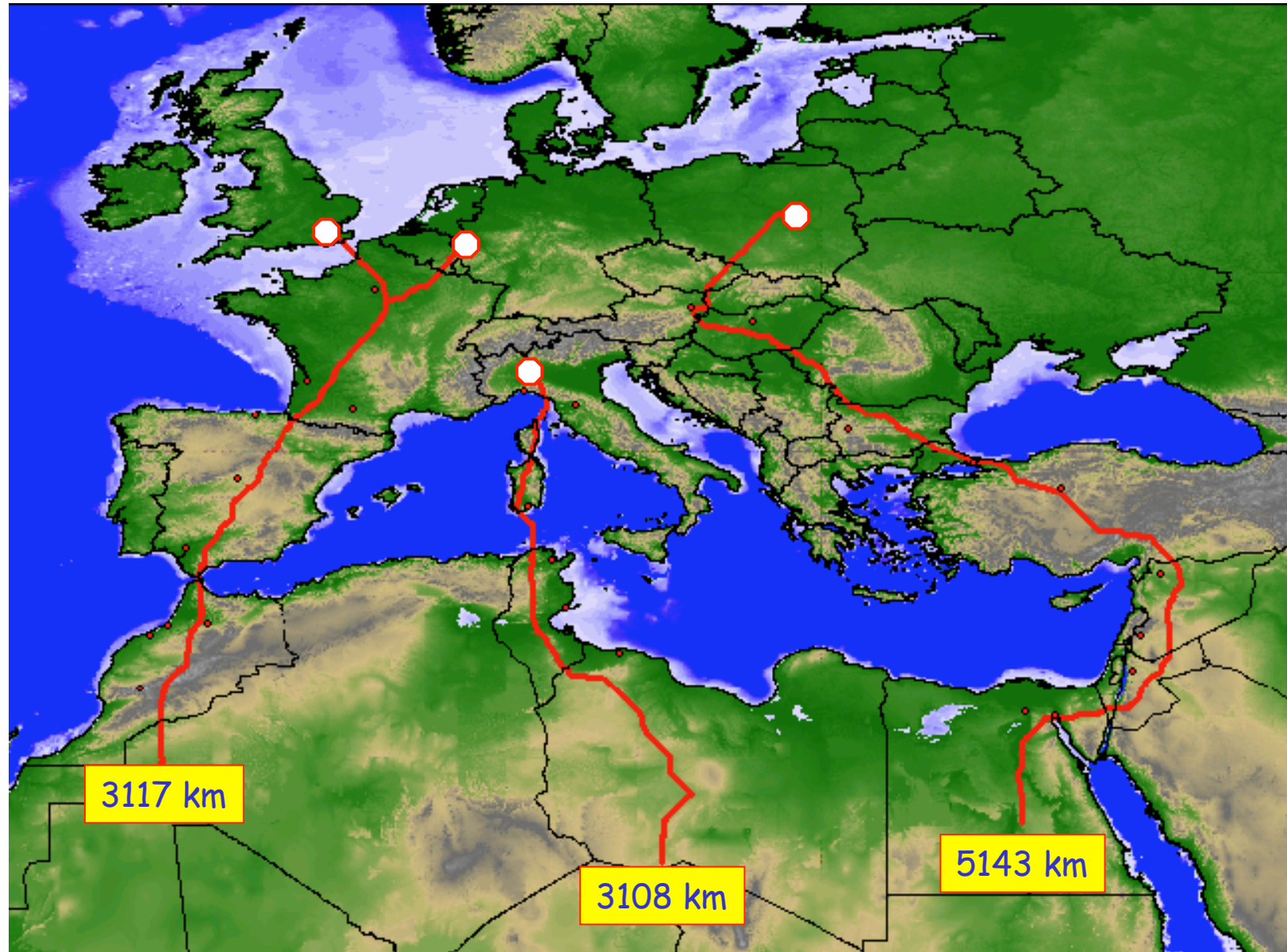

Main properties of high power transmission lines

5 GW transmission lines

(TRANS-CSP Study Report)

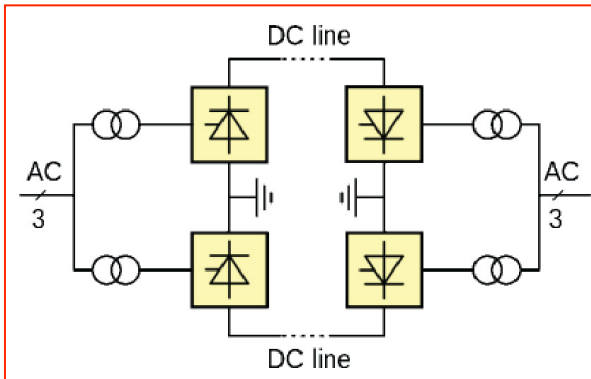

Parameter	Unit	HVAC		HVDC	
		750	1150	±600	±800
Operation Voltage	kV	750	1150	±600	±800
Overhead line losses	%/1000 km	8%	6%	5%	2.5%
Sea cable losses	%/100km	60%	50%	0.33%	0.25%
Terminal losses	%/station	0.2%	0.2%	0.7%	0.6%
Overhead line cost	M€ 1000 km	400-750	1000	400-450	250 - 300
Sea cable cost	M€/1000 km	3200	5900	2500	1800
Terminal cost	M€/station	80	80	250 - 350	250 - 350
<i>Ohmic loss, GW for 3600 km @ 10 GW</i>		<i>2.92</i>	<i>2.2</i>	<i>1.94</i>	<i>1.02</i>
<i>Capital for 3600 km, 10 GW, G€</i>		<i>1.60-2.86</i>	<i>3.76</i>	<i>1.94 -2.32</i>	<i>1.40-1.96</i>
<i>Ohmic (70 TWh/y, .06 €/kWh, 10 y), G€</i>		<i>12.3</i>	<i>9.24</i>	<i>8.15</i>	<i>4.28</i>

- Assume a 3600 km long overhead line with 10 GW peak power and a ohmic loss of 10% (1GW).
- At 800 kV the current is 6.25 kA, the total resistance 51.2 ohm and the total Al mass of 125 kt (34.8 kg/m), to which one has to add 580 kt (163 kg/m) of Steel and 1.5 Mt(400kg/m) of Concrete

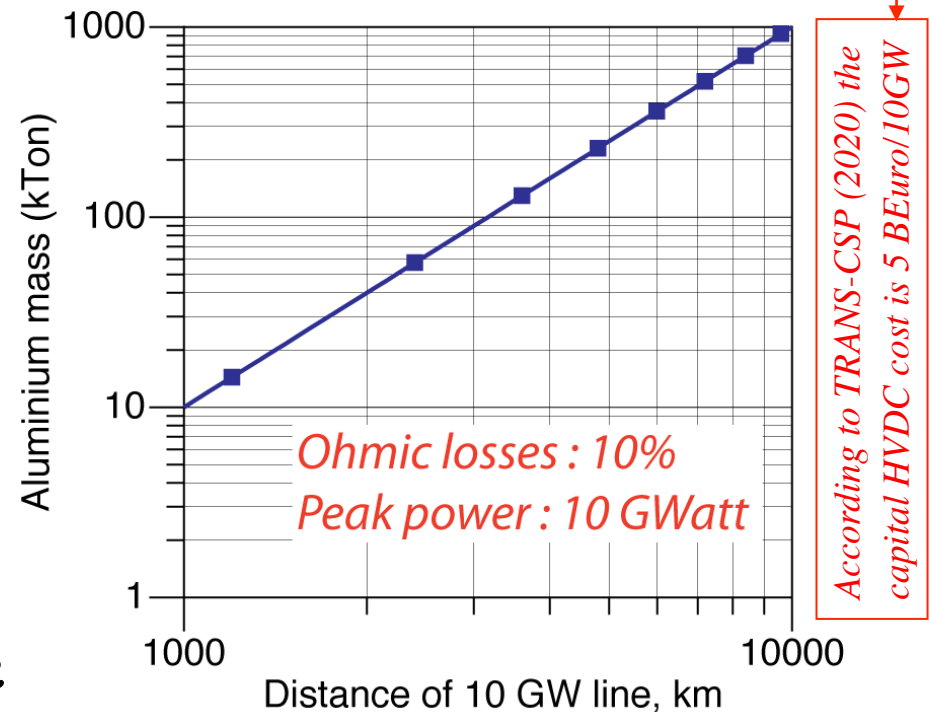

Conventional high power lines

- Overhead lines can be safely constructed but are tall, massive and unsightly.
- The typical capital investment for 10 Gwatt, ± 800 kV and 3600 km is **5 G€**, and ohmic losses are about **0.5 G €/y**
- In the MENA project from Sahara, 10 GW require 225 km² of CSP, but as much as 360 km² of overhead lines !
- In submarine or congested areas sections, cables are needed.
- DC mode is mandatory because of cable added capacitances.
- Heating and ohmic losses limit a single cable to about 1 GW.
- Cable costs are much larger, ≈ 5 -10 times overhead cables.
- Insulations are made with oil impregnated paper, polypropylene: a lower practical voltage (± 500 kV) ?

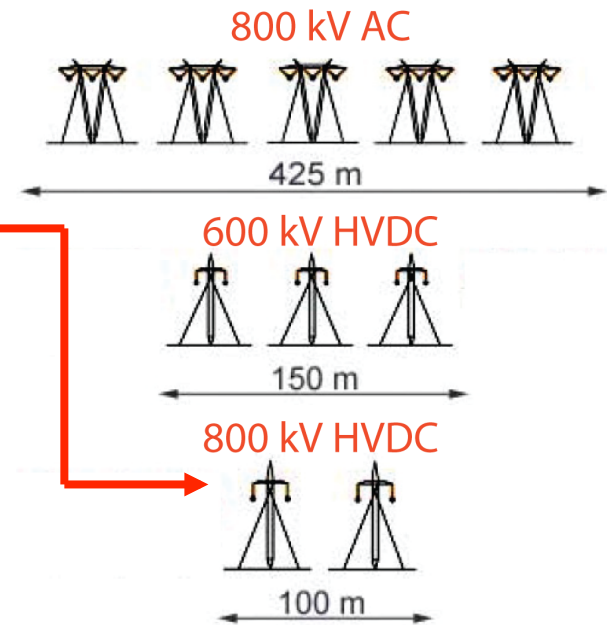

Superconducting lines ?

- Superconductivity was discovered by Kamerlingh-Omnes in 1911. It was already in 1915 that he proposed a first persistent current loop between Paris and London.
- Richard Garwin and Juri Matisoo laid the foundations of the present day options for SC power over very long distances

Nominal power: 100 GWatt over 1000 km

ABSTRACTED TABLE I FROM GARWIN-MATISOO [1], COMPARING VARIOUS COMPONENT COSTS OF A 1000 KM, Nb-Sn CABLE IN 1966 AND NOW

Item	Description/Quantity	1966 Cost (M\$)	2006 Cost (M\$)*
Superconductor	10 ⁴ Tons Nb ₃ Sn	550	3405
Line Refrigeration	0.5 M\$ for 1 kW LHe station every 20 km	25	155
End-Station Refrigeration	10 kW each	5	31
Vacuum Pumps	\$500 per station (2000)	1	6
Fabricated Metal	\$1/lb, linear line weight = 100 gm/cm	20	124
Concrete	\$10/yd ³ for a total volume of 0.5 yd ² times 1000 km	5	31
ac/dc Converters	Thyristors at \$1/kW	200	1238
Total:		806	4990

*2006 costs relative to 1966 are estimated from the Bureau of Labor Statistics table of annual Consumer Price Indices that can be found at <ftp://ftp.bls.gov/pub/special.requests/cpi/cpi.ai.txt>. The 2006/1966 ratio used above is 6.19

P. M. Grant

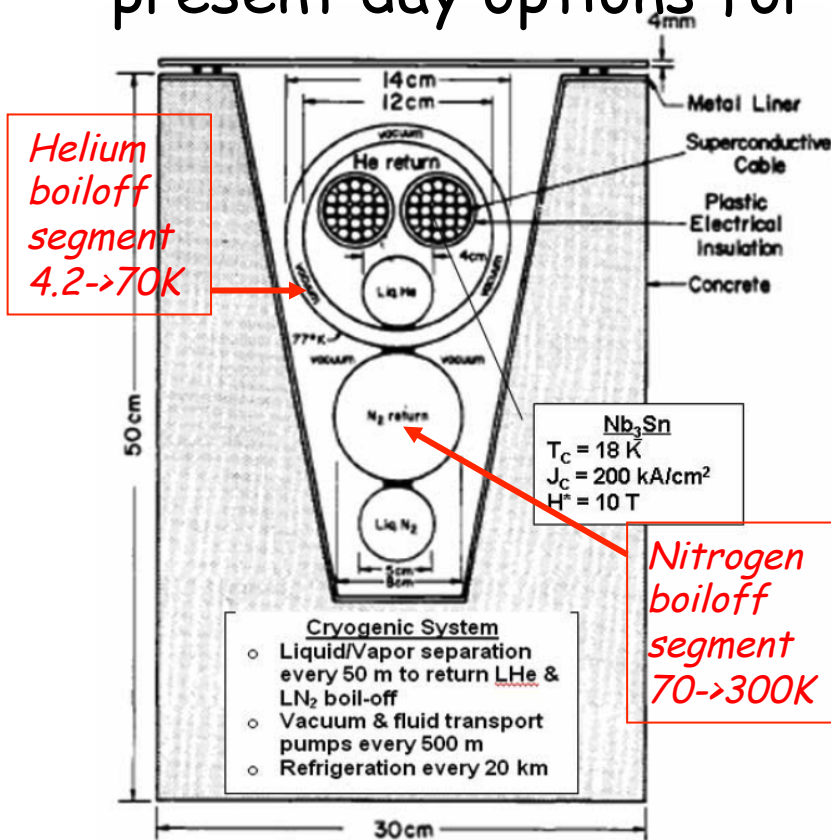

Scaling G.M. + Grant to 10 GWatt

- Scaling SC proportionally to power and same cryogenics linear cost/km gives the following GM costs at 3600 km and 10 GW:

- ⇒ 50 kA at ± 100 kV
- ⇒ Nb₃Sn at 4.3 K
- ⇒ N₂ secondary cooling at 77 K
- ⇒ Refrigeration every 20 km (60 km ?)
- ⇒ Capital cost: 2.6 G € for 3600 km

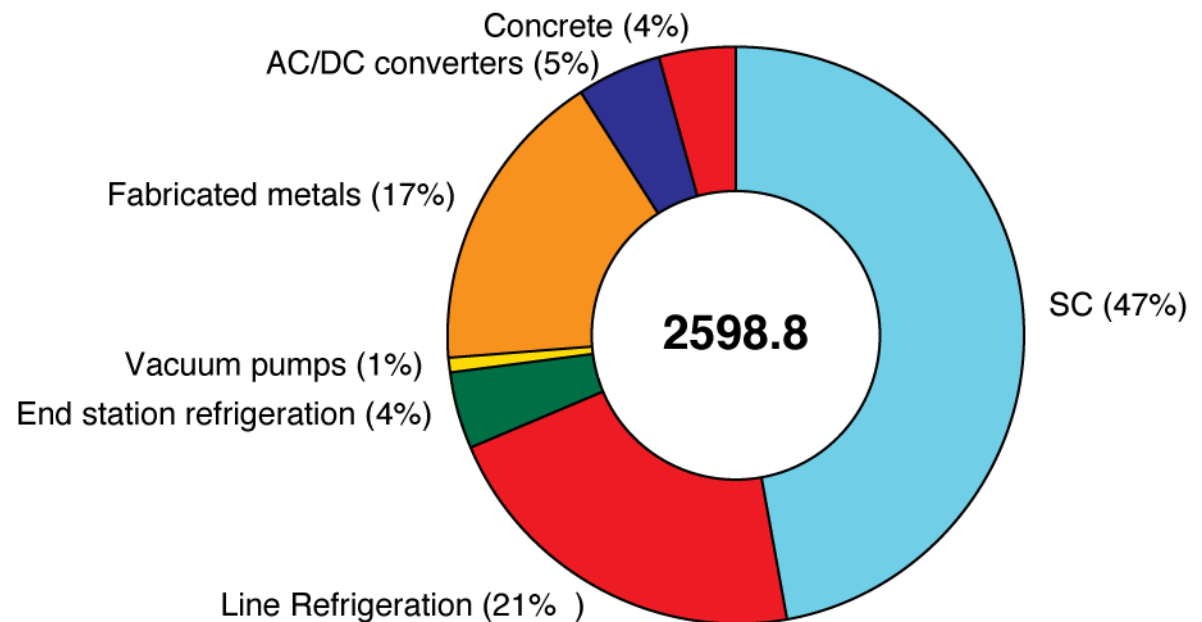

- Capital costs probably underestimated.
- NbTi is a better choice in view of the low magnetic field
- Consumption He: 72 kW_{@4.3K}, 3.46 kg/s, $\approx 72 \cdot 500 = 36$ MW_{@300K}
- Fractional He work : 36MW/10GW=0.36 % (N₂ to be added !)

Today's choices of superconductors: Nb-Ti

- NbTi is the most used SC, in our case with Cu stabilization.
- The LHC alone has produced 7000 km of wire with 50 kA J_c field at 8 Tesla, about the annual world production.
- We assume HV=500 kV, corresponding to a current of 20 kA.
- For $2r = 18$ mm, $I=2 \times 10^4$ A, $B = 0.44$ T (4400 G). Therefore the magnetic field intensities are generally very modest.
- $J_c(B, T)/J_c(5T, 4.2K)$ is shown for a typical LHC Nb-Ti strand
- A J_c increase of about one order of magnitude is observed
- For our conductor length of 2×3600 km and with $J_c \approx 50$ kA (for safety) **only about 10% of LHC supply is necessary.**

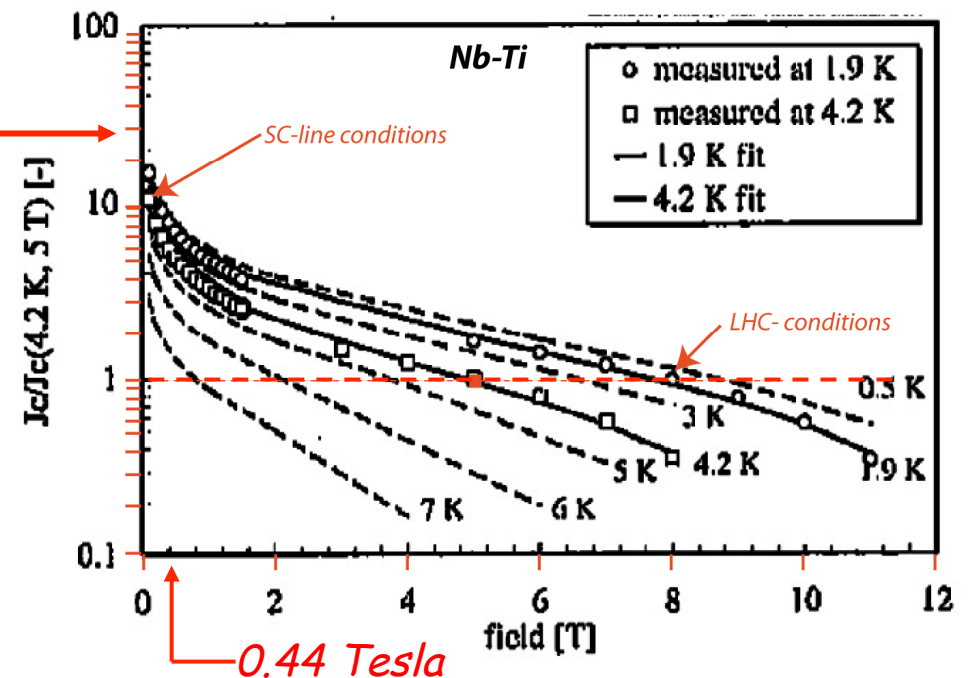

Today's choices of superconductors: MgB_2

- MgB_2 is still under development and relatively small quantities of cable with such SC have been manufactured so far, basically at laboratory scale.
- However there is a general consensus that there is no show stopper to increase the production to a rate capable of fulfilling the present requests.
- An interesting alternative to be studied is the one of boiling liquid hydrogen cooling, since such a solution is in principle feasible and applicable to MgB_2 .
- Operational up to 30 K.
- Example of a cable from CERN/Columbus
- $J_c \geq 500 \text{ A/mm}^2$ at 0.44 T
- $72 \times 600 \text{ A} = 43.2 \text{ kA}$, adequate for $I=20 \text{ kA}$ (10GW) operation.

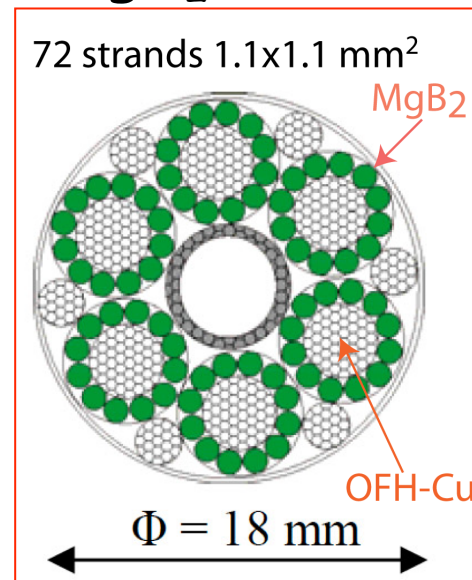

So called Amalia cable

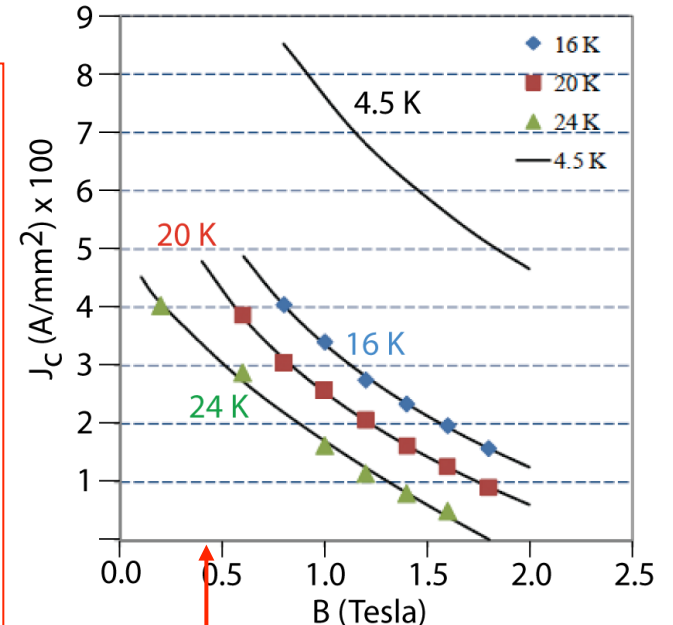

0.44 Tesla

Slide# : 10

Today's choices of superconductors: HTSC

- Both solutions, Bi-2223 (1G) and Y-123 (2G) look possible and have similar current characteristics and temperature range.
- In view of the potential for cost reduction more work is being put into developing Y-123 in form of coated conductor, so this material is now preferred for new cable studies.
- The high cost of the superconductor is a limitation. Bi-2223 is up to 50 times more expensive than Nb-Ti [$\approx 1\text{€}/(\text{kA m})$ at 8 T]
- The main advantage is cooling at the temperature of liquid N₂
- Cable properties are of concern since they have a considerable mass and need to withstand big forces during handling.
- There are hopes that future prices may be substantially reduced

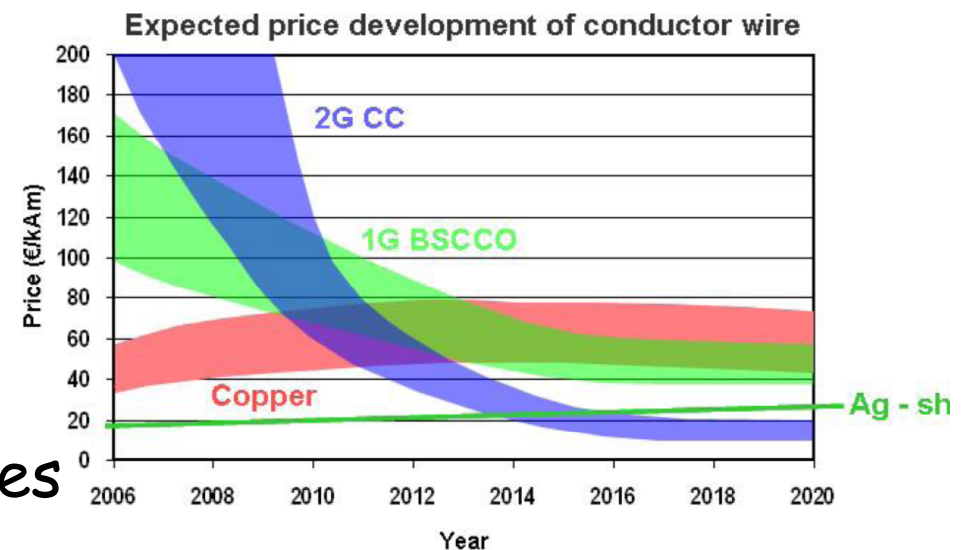

YBCO tape and Cable

YBCO tape

Tape width	= 4 mm
Tape thickness	= 0.1 mm
J_e	= 15000 A/mm ²
T_{op}	= up to 70 K
T_{max}	= 73 K
T_{margin}	= 3 K
$B_{peak} // ab \text{ plane}$	= 0.8 T
Cable inductance	~ 10 μ H/m

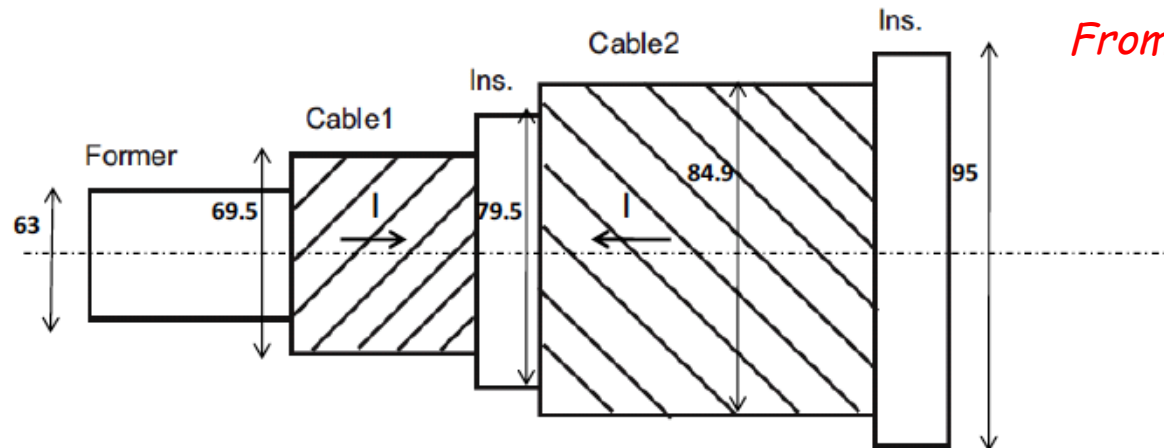
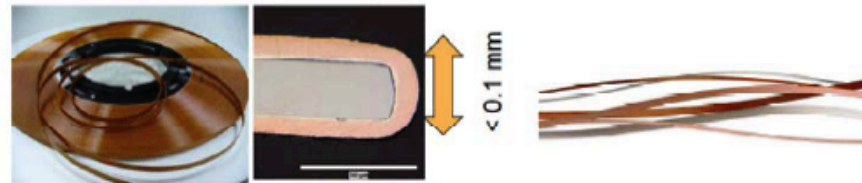
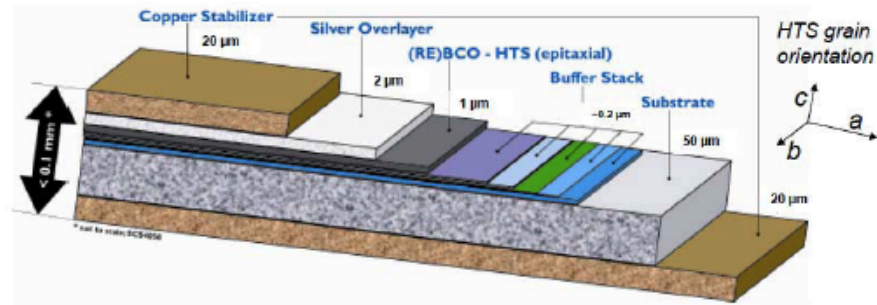

*From CERN study group
February 2010*

sketch of the HTS (Y-123) cable and sub-elements.

Choosing the coolant

- Three cryogenic liquids are under consideration, He, H₂ and N₂

. Vaporization and specific heat at boiling temperature and std. pressure.

Element		Temp.		Vaporiz. heat		Density	Specific heat, C_p	
		A	K	kJ/kg	kJ/litre	g/cm^3	kJ/kg C	kJ/litre
Helium	He	4.00	4.25	20.28	2.51	0.124	4.545	0.56
Hydrogen	H ₂	2.02	20.35	446.0	31.67	0.071	9.668	0.69
Nitrogen	N ₂	28.01	77.35	199.1	160.87	0.808	2.042	1.65

- Boiling H₂ has remarkable thermal properties, namely a larger vaporization heat of 446 kJ/kg, to be compared with 20.28 kJ/kg for He and 199.1 kJ/kg for the much denser N₂.
- Monophase liquid He-1 is only possible from 4 K to 5 K, while both H₂ and N₂ have large pressure dependent liquid interval.

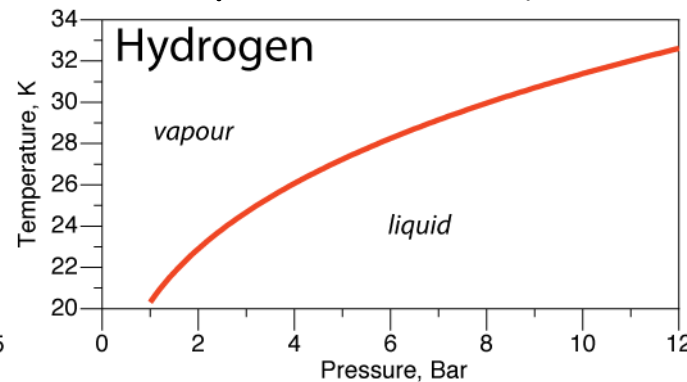
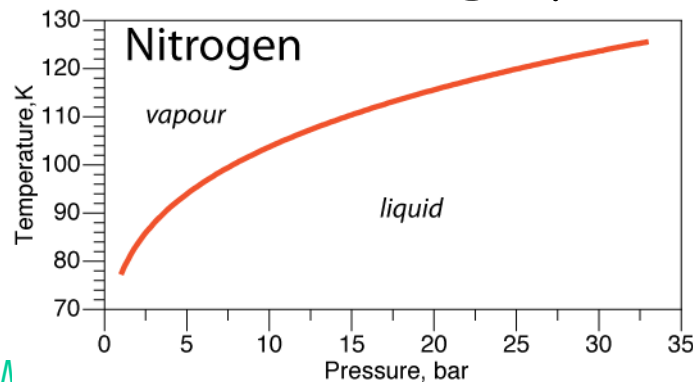

A key element: an effective Super-Insulation

- For DC conditions the heat transport to the line is dominated by radiation through the Stefan-Boltzmann constant.
- Multilayer mylar with spacers is commonly used in order to reduce the radiative heat load in good vacuum conditions.
- The radiated heat H (W/m^2) is well described by an empirical formula, evaluated from measurements of heat influx through $N \approx 30$ mylar layers at temperature T_1 from temperature T_2

Heat transmission in W/m^2 through multilayer mylar.

Alternative	T1(K)	T2(K)	N layers	H (W/m^2)
He to 77 K	4.2	77	30	0.042
H2 to 77 K	21.	77	30	0.040
H2 to to Room Temp.	21.	300	30	1.235
He to Room Temp.	4.2	300	30	1.238
N2 to to Room Temp.	77.	300	30	1.195

- The mechanical work from radiating temperatures T_1 to 300 K is given by the (inefficient) Carnot cycle. Ratios 470, 69 and 9.65 have been assumed for $T_1 = 4.2, 21$ and 77 K to 300 K

Cooling power (3600 km)

- The dominant cryogenic radiated heat H (W/m^2) is caused by the inevitable heat flow to room temperature (T_2), largely independent from the value of the cryogenic temperature T_1 .
- However the electric power W_{ele} is strongly influenced by the value of T_1 , related to the efficiency of the Carnot cycle.

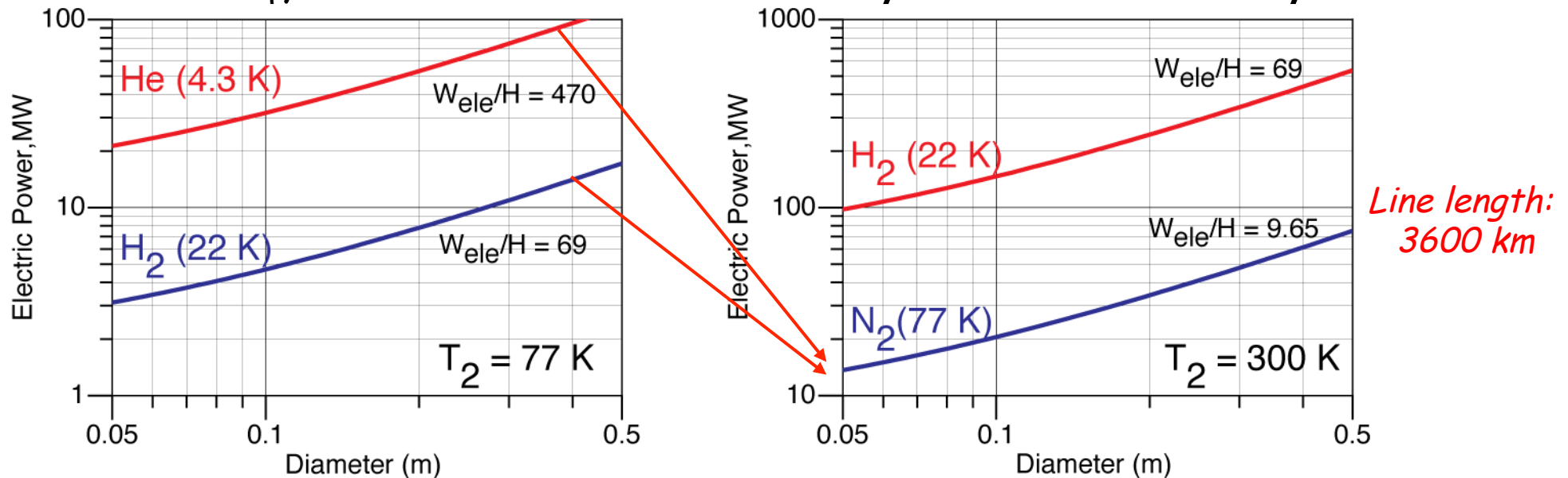

- Shown as a functions of the outer tube diameters, H₂ and He to 77K (left) and He and H₂ and N₂ to 300K (right). The case H₂(22K) at T₂=300K is without N₂ cooling, otherwise required.

The G-M cryogenic system is very elaborated

- The Garwin-M method was based on He and N₂ both boiling :
 - ➔ continuous separations of liquid to vapour every 50 m
 - ➔ a very frequent (every 500 m) vacuum and circulating pumps
 - ➔ A main refrigeration station every 20 km.
 - ➔ Additional, double phase N₂ coolant from 70 to 300 K

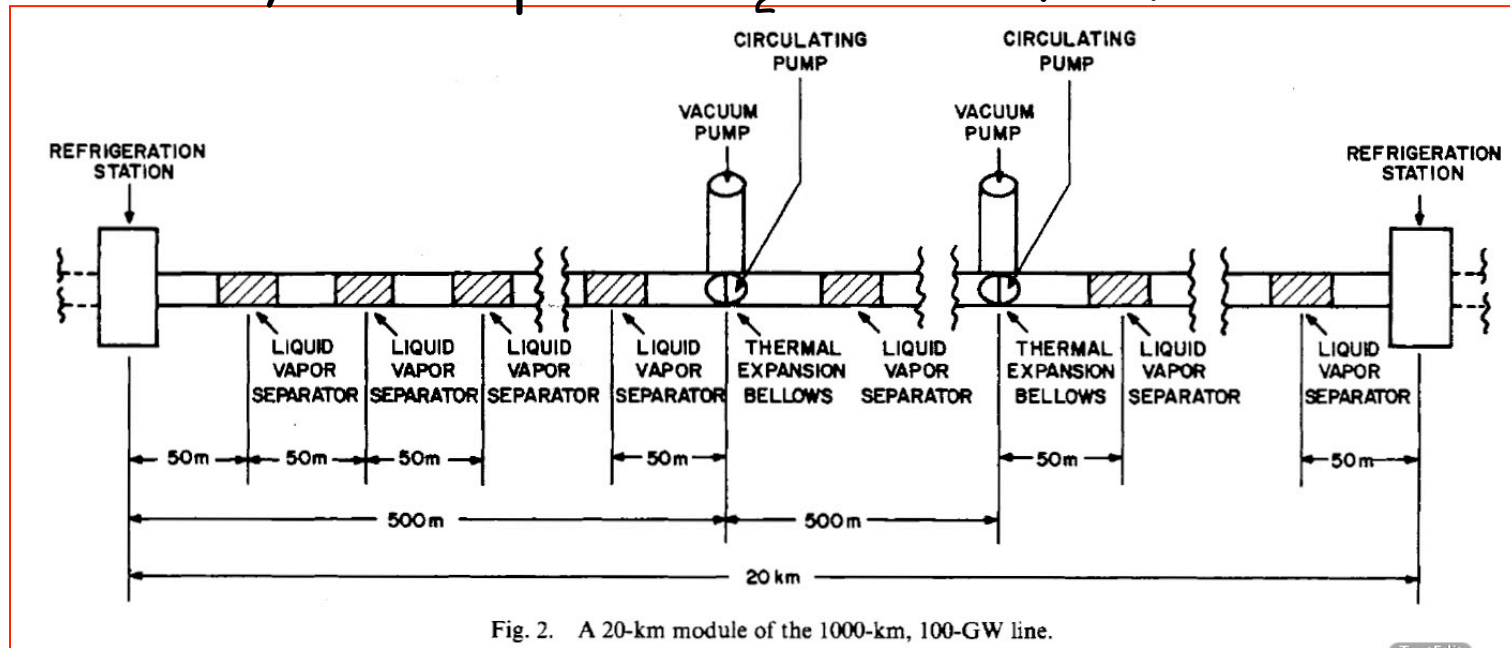

- H₂ and/or N₂, no He and higher temperatures SC may offer much simpler systems based on single phase, liquid coolants.

Single phase Liquid N₂ (either secondary or HTSC)

- Liquid N₂ is cooling from 70 K to 300 K.
- Single phase mode: transported at all times as a liquid, increasing slowly the temperature as a function of the length along the local segment.
- Several inner structures to 70K :
 - ➡ Boiling He, but on shorter distance
 - ➡ HT-SC directly at ≈70 K
 - ➡ Boiling or single phase H₂ at ≈20K

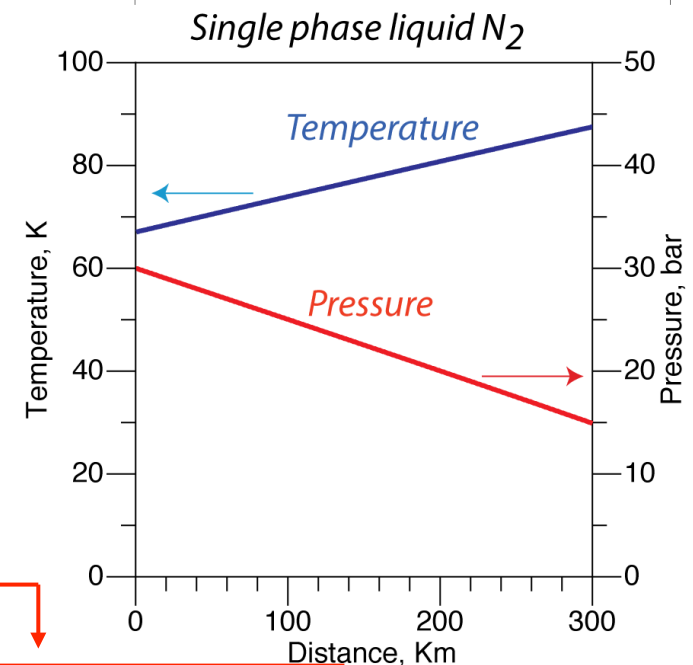
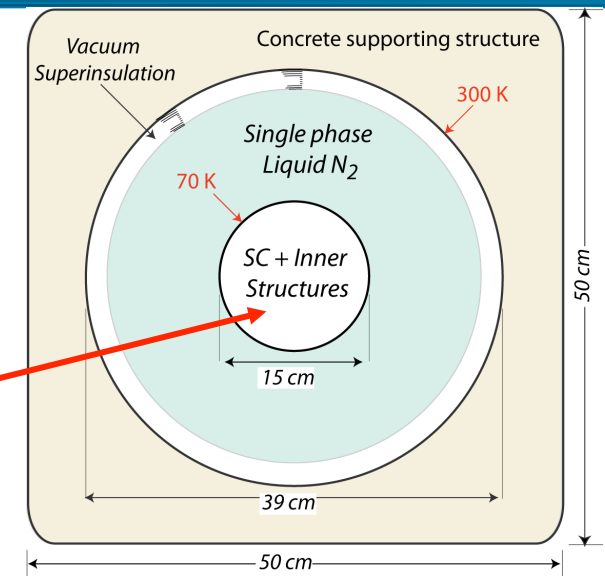

Inner tube:	0.1500	m
Outer tube:	0.3500	m
Hydraulic diameter:	0.2000	m
Length of tube:	300.0	km
Initial Temperature:	67.00	K
Final Temperature	87.47	K
Initial Pressure:	30.00	bar
Final Pressure	14.92	bar
Transfer time	199.6	h
Heat leak to 300 K:	1.200	W/m ²
Mass flow(h):	36.0	ton/h
Total N ₂ heat loss/300km	395.8	kWatt

SC Workshop_May2011 Relatively large consumption of N₂ because of losses at 300 K

Slide# : 17

Single phase H₂ only system

- A remarkably simple structure: an inner volume filled with liquid H₂, SC-MgB₂ and high voltage insulators, followed by 30-60 metallized mylar super-insulation layers up to room temperature
- The superinsulation is under high vacuum, ensured by (distributed) ion titanium pumps.
- Mechanical stability is ensured by the concrete supporting structure
- Very long distance between stations (up to 300 km)

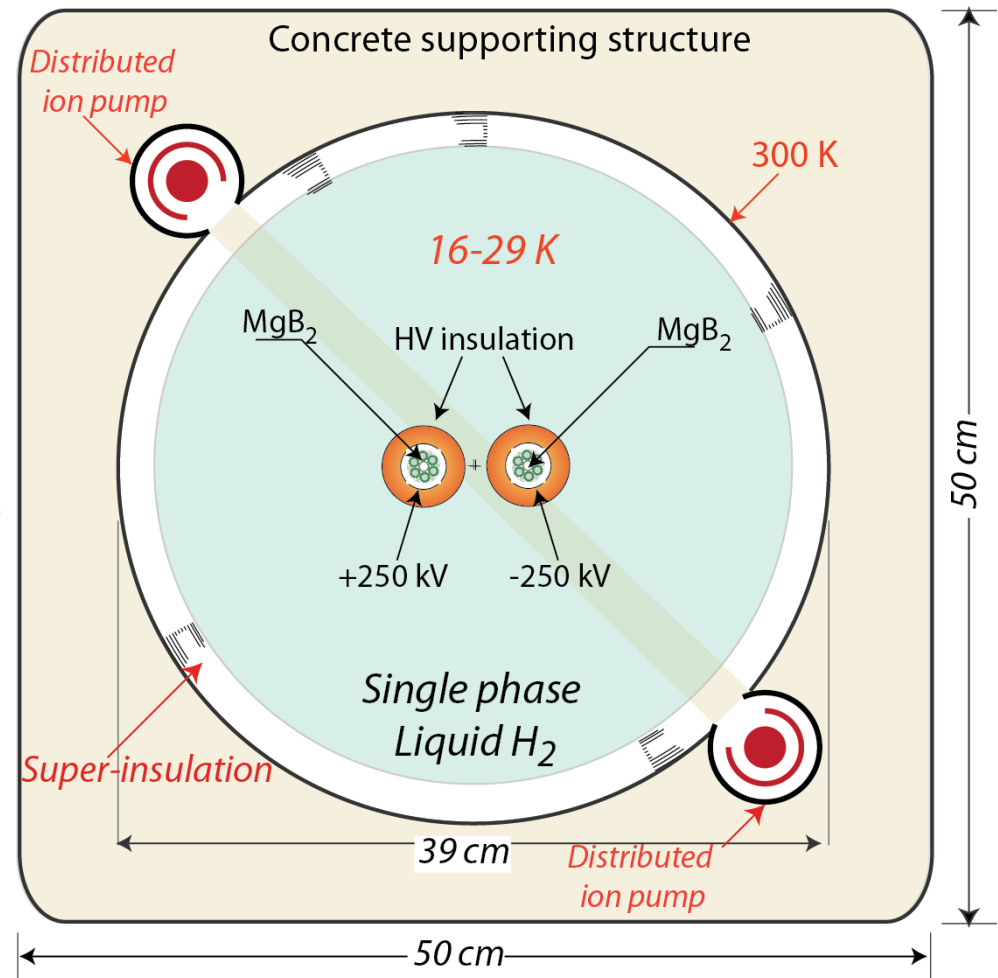

Enough space in the SC segment for a 20 GW nominal power

Single phase H2 coolant

- Single phase H₂ from 16 to 300 K *without additional N₂ coolant* has much larger heat losses (10 t/h) and 1.2 W/m² with 30 layers of super-insulation. However improvements are possible !
- However the coolant mass is smaller than for pure N₂ case. *H₂ at 25 K: C_p=11.7 kJ/kg/K. N₂ at 79 K: C_p=2.05 kJ/kg/K*
- Relatively insensitive to pressure changes due to vertical height variations (± 1 km with ± 7 bar)

Inner tube:	0.070	m
Outer tube:	0.35	m
Hydraulic diameter:	0.28	m
Length of tube:	300.0	km
Initial Temperature:	16.00	K
Final Temperature	29.49	K
Initial Pressure:	20.00	bar
Final Pressure	17.71	bar
Transfer time	110.8	h
Heat leak to 300 K:	1.20	W/m ²
Mass flow	10.0	ton/h
Vertical depth for +5 bar	740.0	m
Total H ₂ heat loss/300km	396.	kWatt

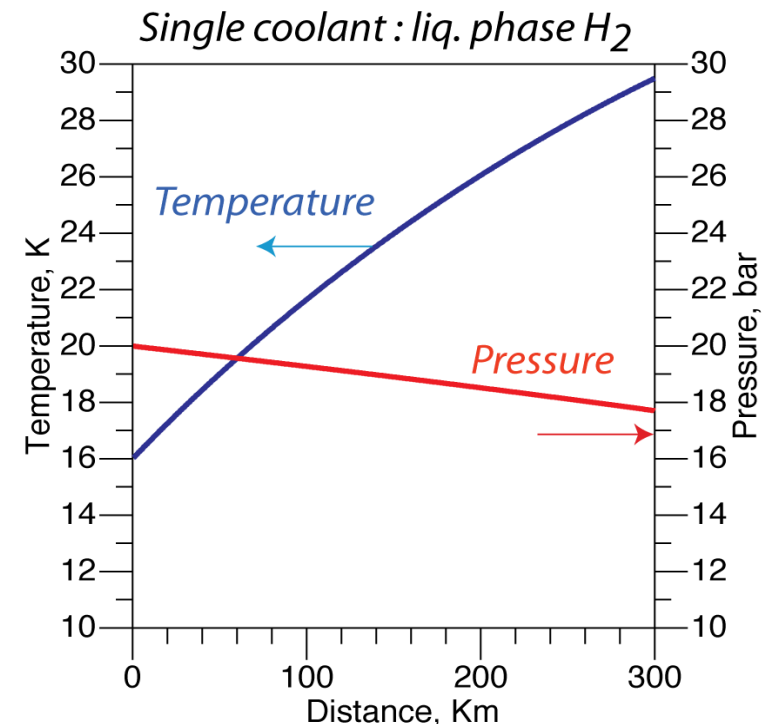

Single phase H₂ to 300 K

- Dimensions of cryostats for different sector's lengths
- Specific cryogenic powers and H₂ mass flows are also shown
- Single phase H₂ is cooled from initial to final H₂ temperatures with help of cryo-coolers

<i>Length of each sector</i>	50	100	300	km
H ₂ outer diameter	14.0	18.0	35.0	cm
External diameter	18.0	22.0	39.0	cm
Initial H ₂ pressure	20.0	20.0	20.0	bar
Final H ₂ pressure	15.0	14.1	17.7	
Initial H ₂ temperature	16.0	16.0	16.0	K
Final H ₂ temperature	26.3	26.7	29.5	K
Specific cryogenic power	527.8	678.6	1320	W/km
H ₂ specific mass	20.16	25.2	33.6	kg/(h km)

Relative diameters

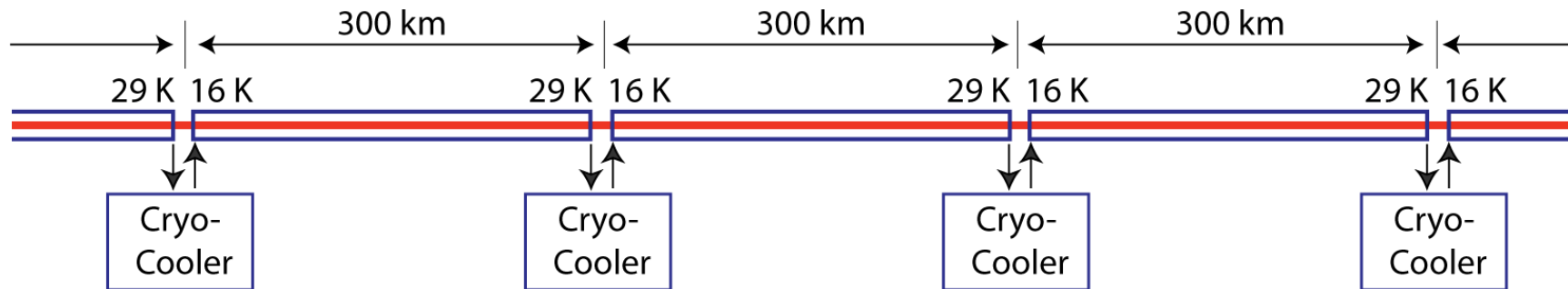
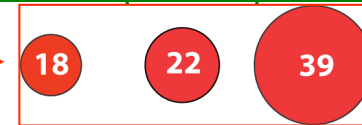

- The mechanical work is given by the (inefficient) Carnot cycle $W_{out} = W_{in} / E \times (T_2 - T_1) / T_1$ with $T_2 = 30$ K, $T_1 = 16$ K and $E \approx 0.1 - 0.2$?

Conclusions

- Significant innovations justify new approaches of high power SC lines for distances and powers which cannot be otherwise economically realized by any other method.
- In spite of its recent discovery, MgB_2 has already shown its full potential as a superconductor which may represent a logical step of evolution in the upcoming years for most of the applications which are now counting on Nb-alloy SC **and while waiting for the Cuprate HTS to reach their targets.**
- MgB_2 with single phase liquid hydrogen with or even without additional single phase N_2 coolant offers major simplifications with respect to classic Nb-alloys and boiling $\text{He} + \text{N}_2$, with practical distances of up to several hundred km.
- Vertical height variations even of substantial magnitude can be compensated by changes of the H_2 pressure.
- A high reliability of the system may be ensured with an **appropriate high redundancy** of the relevant components.

Thank you !

Single phase H₂ to 70 K, followed by N₂ to 300 K

- Transport segment, 300 km long
- Single phase H₂ between 16K and 70 K, with external N₂ secondary coolant.
- MgB₂ SC with J_c ≈ 43.2 kA, adequate for I=20 kA (10 GW) operation. Enough space for doubling SC material up to 20 GW.
- Modest H₂ consumption of ≈ 5 kW cold.
- Vertical depth due to the much denser N₂

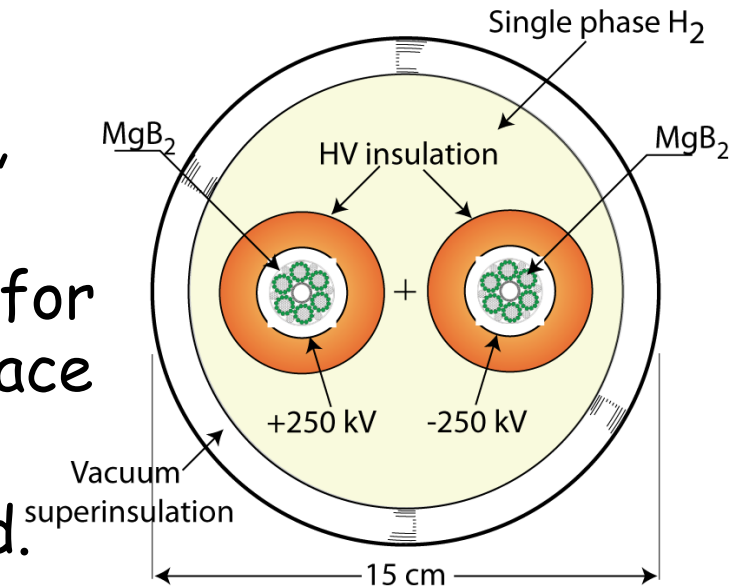

Inner tube:	0.064	m
Outer tube:	0.13	m
Hydraulic diameter:	0.066	m
Length of tube:	300.0	km
Initial Temperature:	16.00	K
Final Temperature	27.59	K
Initial Pressure:	10.00	bar
Final Pressure	8.99	bar
Transfer time	438.0	h
Heat leak to 300 K:	0.039	W/m ²
Mass flow	144.0	kg/h
Vertical depth for +5 bar	740.0	m
Total H ₂ heat loss/300km	4.876	kWatt

